

# TYPE RR , SILICON CARBIDE HEATING ELEMENTS

## GENERAL DESCRIPTION

The RR Starbar is a resistance type silicon carbide heating element. Starbars are rod shaped or tubular depending on the diameter. They have a central heating section referred to as a hot zone and two terminal sections called cold ends. There are two types of RR Starbars. (1) The cold ends are impregnated with silicon metal -- referred to as *one piece*, and (2) low resistance cold ends which are furnace welded to the hot zone -- referred to as a *three piece* or LRE (Low Resistance End) type. This lower electrical resistance cold end causes them to operate at a lower temperature. The extremities of the elements are metallized with aluminum to provide a low resistance contact surface to which the electrical connections are made using braided aluminum straps.

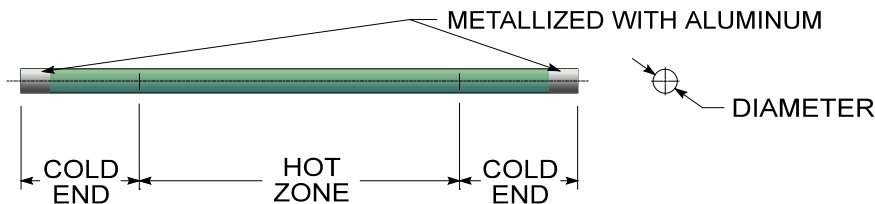

RR Starbars are described by giving the overall length, the heating section length, and the diameter. As an example, RR 43 x 24 x 1 is a Starbar 43" overall with a 24" hot zone, and 1" in diameter.

## SUPERIOR PERFORMANCE

Starbars will give you superior performance due to their high density -- approximately 2.4 gms/cc. This gives the Starbar very slow aging characteristics and additional strength.

## INTERCHANGEABILITY

Starbars are interchangeable with all silicon carbide heating elements manufactured in the United States as well as higher resistance heating elements manufactured for the Asian and European markets. It is important to provide the nominal electrical resistance when ordering Starbars. Please contact us, before attempting to substitute

## SIZES AVAILABLE

Starbars can be manufactured in any length up to 228 inches (5800mm). The maximum hot zone length is 166 inches (4216mm).



## Silicon Carbide Heating Elements



FOURS ET RÉFRACTAIRES

92 à 96 rue Paul Lescop  
F 92000 Nanterre - France  
Tél. 33 (0)1 47 21 13 17  
Fax. 33 (0)1 47 24 54 92  
contact@refsas.com  
[WWW.REFSAS.COM](http://WWW.REFSAS.COM)



S.A. au capital de 545 000€  
RCS Nanterre B 679 800 615  
SIRET : 679 800 615 00040  
NAF : 2320Z

ARCHITECTE DU CHAUD SUR MESURE

## Recommended Maximum Watt Loading (Figure 1)

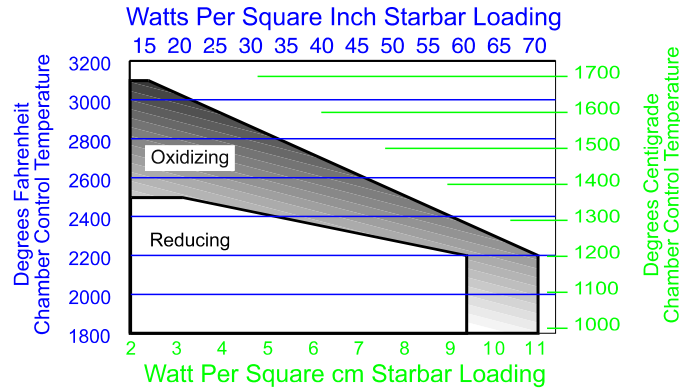

### OPERATING TEMPERATURES

In an air or inert atmosphere of argon or helium the one piece Starbars can be operated at furnace control temperatures up to 3100°F (1700°C), the *three piece* Starbar up to 2600°F (1425°C). In reducing atmospheres the maximum operating temperature is 2500°F (1370°C), see Figure 1. There is a protective coating of silicon dioxide on the silicon carbide. Hydrogen reduces this coating and causes the Starbar to deteriorate. Very dry or very wet hydrogen is detrimental to long service life.

Nitrogen atmosphere applications are limited to 2500°F (1370°C) and 20 to 30 watts per square inch (3.1 to 4.6 watts per square centimeter) maximum surface watt loading. Too high of a surface temperature will result in a silicon nitride reaction. A thermally insulative layer forms around the Starbar resulting in very high surface temperatures which damage the Starbars.

### ELECTRICAL CHARACTERISTICS

The silicon carbide Starbar is a linear type resistance heater that converts electrical energy to heat energy -- Joule's Law  $W = I^2 \times R$ , ( $W$  = power in watts,  $I$  = current in amperes,  $R$  = resistance in ohms).

The Starbar hot zone is a self bonded silicon carbide. The lattice structure or bonds that hold the silicon carbide grain together are formed by recrystallizing the silicon carbide at very high temperatures. Starbars are manufactured of green silicon carbide that is classed as an excess electron type semiconductor.

The electrical resistance of a Starbar is difficult to measure at room temperature due to minor impurities, self heating, and contact resistance. Also the green silicon carbide has a negative resistance temperature characteristic from

### Resistance Temperature Characteristics (Figure 2)

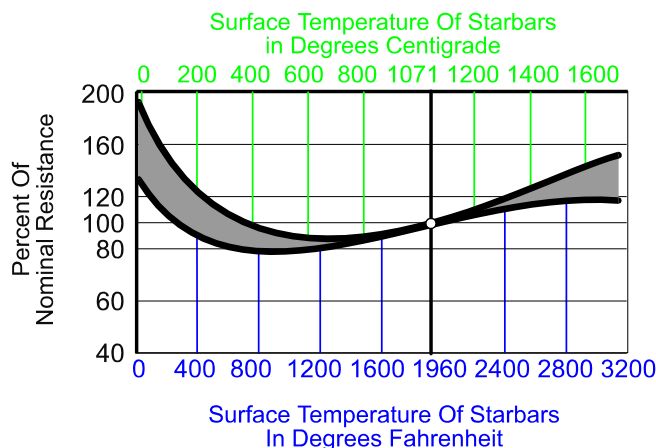

Starbars are test calibrated at a nominal surface temperature of 1960°F (1071°C).

room temperature to approximately 1200°F (650°C). It turns positive at this point and remains so throughout its normal operating temperature range. A typical resistance temperature characteristic curve of a Starbar is shown in Figure 2.

Nominal Starbar resistance is measured at the calibrating temperature of 1960°F (1071°C). Nominal resistance values of Starbars in ohms per unit of length are shown in Table A, page 5.

## ELECTRICAL LOADING

Starbars are not sized to a specific wattage output like metallic heating elements. The amount of energy that a Starbar is capable of converting from electrical to heat energy depends on the ambient furnace temperature and atmosphere in which the Starbar is operating.

When calculating the wattage capabilities of a Starbar, the unit of watts output per unit of radiating surface area is used. Figure 1 shows the recommended watt loading for a square inch or square centimeter of radiating surface as a function of furnace temperature.

To determine the recommended wattage capabilities of the Starbars start with Figure 1, knowing the furnace temperature and atmosphere in which the Starbars will be operated. Follow the temperature line until you intersect the heavy black line (choosing the appropriate line according to the atmosphere in which the Starbar will be operating). Read the loading in watts per square unit of radiating surface that can be applied to the Starbar. To find the total amount of power one Starbar could supply under these conditions, multiply this value by the radiating surface of the Starbar. The radiating surface area is calculated by multiplying the diameter times the hot zone length times pi (3.14).

Example: At 2750°F the Starbar could be loaded to 35 watts per square inch. Therefore, a Starbar with 10 square inches of radiating surface could supply 350 watts, whereas a Starbar with 200 square inches of radiating surface could supply 7000 watts.

(At 1500°C the Starbar could be loaded to 6 watts per square centimeter. Therefore, a Starbar with 100 square centimeters of radiating surface could supply 600 watts, whereas a Starbar with 2000 square centimeters of radiating surface could supply 12,000 watts).

Example of radiating area:

The RR 43 x 24 x 1 has a hot zone length of 24 inches on a diameter of 1 inch. The radiating surface area is 24 x 1 x 3.14, or 75.4 square inches. (The RR 1092 x 610 x 25 has a hot zone length of 610mm and a diameter of 25mm. The radiating surface area is 610 x 25 x 3.14 or 47,885 square mm, converted to centimeters is 478 square centimeters).

## POWER SUPPLY

In the previous paragraph we explained how to calculate the recommended wattage output of the Starbar. Now we shall explain how to compute the electrical requirements to provide the recommended power.

Knowing the wattage output and the resistance of the Starbar you have two parts of an equation with three unknowns. This equation is  $E = \sqrt{(W \times R)}$ , (E = nominal full load voltage, W = rating of the Starbar in watts, R = resistance of the Starbar in ohms). The resistance of the Starbar can be calculated using the values found in Table A.

When solving for E, you would obtain the voltage required on a nominal resistance Starbar to provide the wattage output desired.

Example: A Starbar RR 43 x 24 x 1 has a resistance of 1.21 ohms and 75 square inches of radiating surface. Loading to 40 watts per square inch, this Starbar could provide 3000 watts. To find the nominal voltage solve for E.

$$\begin{aligned} E &= \sqrt{(W \times R)} \\ E &= \sqrt{(3000 \times 1.21)} \\ E &= 60 \text{ volts} \end{aligned}$$

Starbars may be connected in parallel, series, or combination thereof. Parallel connections are preferred.

In a parallel arrangement the voltage across all the Starbars is the same. In the formula  $W = E^2 \div R$ , (W = watts, E = voltage, R = resistance) it can be seen that the greater the resistance, the lower the wattage output. The Starbars in the parallel circuit with the lowest resistance will supply more heat energy and therefore operate at a higher temperature. This higher Starbar temperature will cause it to gradually increase in resistance until all the Starbars have the same resistance. At this time the Starbars should all have approximately the same resistance values and surface temperatures and therefore remain in balance.

To compute the network resistance of a group of Starbars the following formula may be used:  $R_n = R \times S \div P$  ( $R_n$  = network resistance, R = resistance of Starbar, S = number of Starbars connected in a series, P = number of parallel circuits).

Example: Eight Starbars RR 43 x 24 x 1 (R = 1.21 ohms) connected 2 in series (S = 2) and 4 parallel groups (P = 4).

$$\begin{aligned} R_n &= R \times S \div P \\ R_n &= 1.21 \times 2 \div 4 \\ R_n &= 0.6 \text{ ohms} \end{aligned}$$

To compute the nominal voltage required to power a set of Starbars, we shall use a combination of the formulas used in the two previous examples.  $E_n = \sqrt{W_t \times R_n}$ , ( $E_n$  = nominal network voltage,  $R_n$  = network resistance,  $W_t$  = total wattage output).

Example: Eight Starbars RR 43 x 24 x 1 (R = 1.21 ohms) connected 2 in series, 4 parallel groups. Each Starbar provides 3000 watts.  $W_t = 8 \times 3000 = 24,000$  watts.  $R_n = 0.60$  ohms.

$$\begin{aligned} E_n &= \sqrt{W_t \times R_n} \\ E_n &= \sqrt{24,000 \times 0.6} \\ E_n &= 120 \text{ volts} \end{aligned}$$

The resistance of Starbars increases gradually during their useful life. Therefore, some means of keeping the power input to the kiln or furnace at a level sufficiently high to maintain the desired temperature is required.

Historically, expensive voltage varying equipment such as multiple tap transformers or saturable reactors were recommended for all but the very low temperature applications.

Starbars can be used directly on the line (fixed voltages) at temperatures up to 2400°F (1315°C). To compensate for the reduced output as the Starbars gradually age or increase in resistance, the furnace or kiln is initially overpowered by 25% to 50%. This type of arrangement eliminates the expensive voltage varying equipment and has proven very satisfactory in many applications. It is not recommended when fine process temperature control is required.

Assume a furnace will require approximately 24,000 watts after all heat losses and load factors have been considered. Increasing this 24,000 by 25% to 50% gives a wattage requirement of between 30,000 and 36,000 watts.

By taking another look at the previous examples it can be seen that 10 Starbars RR 43 x 24 x 1 connected two in series, five parallel groups on 120 volts would supply the 30,000 watts. If 12 Starbars of the same size were used, the output would be 36,000 watts. Twelve Starbars connected four in series per phase on 240 volts would make a balanced three phase 240 volt network.

The temperature of the kiln or furnace is controlled by an off-on controller. When the Starbars are new they will only be powered for 24/30 or 24/36 of an hour. As the Starbars increase in resistance they will be on for a greater percentage of the time. When they have increased in resistance to a point at which they supply 24,000 watts, they will be on 100% of the time. A SCR (silicon controlled rectifier) or thyristor can also be used.

For applications where close temperature control is desired and/or for temperatures above 2400°F (1315°C) a device for increasing the voltage to the Starbars is required. There are several methods of providing this variable voltage source:

- (1) The multiple tap transformer is the most common, because it is usually the least expensive. The secondary of the transformer is provided with taps which usually vary in number from 10 to 36. By carefully selecting the voltage taps, the correct voltage output to match the resistance of the Starbars over their complete useful life can be made.
- (2) Saturable reactors and induction regulators are used to provide a stepless voltage control. They are also sometimes used with multiple tap transformers.
- (3) Capacitor controls are used infrequently. They, of course, will tend to improve a power factor, which makes their use desirable in some areas.
- (4) Silicon controlled rectifiers, (SCR) have become quite popular with the advances in solid state devices.

To compensate for the reduced output as the Starbars increase in resistance, a voltage range is required that will compensate for a 100% increase in the Starbar resistance. The following formula may be used to calculate Emax :  $E_{max} = \sqrt{(Wt \times R_n)} \times 1.5$ , ( $E_{max}$  = recommended maximum voltage required to compensate for increase in resistance due to aging and resistance tolerance,  $Wt$  = rating of transformer in watts,  $R_n$  = network resistance of the Starbars, 1.5 = minimum margin to accommodate the doubling of the Starbar resistance and the +20% resistance tolerance). A higher value will offer slightly longer usable service life.

Example: The transformer is rated at 24 KVA and has a computed nominal full load voltage of 120 volts. ( $R_n = 0.6$ ,  $Wt = 24,000$ ).

$$E_{max} = \sqrt{(Wt \times R_n)} \times 1.5$$

$$E_{max} = \sqrt{(24,000 \times 0.6)} \times 1.5$$

$$E_{max} = 180 \text{ volts}$$

<b>Table A</b>							
<b>RR Starbar Dimensions</b>				<b>** RR Electrical Resistance</b>			
Diameter		* Max.Rec. Hot Zone Length		Ohms Hot Zone		Ohms Cold Ends	
MM	Inch	MM	Inch	Ohms / MM	Ohms / Inch	Ohms / MM	Ohms / Inch
10	3/8	355	14	0.01372	0.3486	0.000686	0.01743
11	7/16	355	14	0.01009	0.2563	0.000505	0.01282
13	1/2	560	22	0.00773	0.1963	0.000387	0.00982
16	5/8	610	24	0.00497	0.1262	0.000248	0.00631
19	3/4	863	34	0.00341	0.0865	0.000170	0.00433
25	1	1220	48	0.00197	0.0500	0.000098	0.00250
32	1-1/4	1524	60	0.00134	0.0343	0.000067	0.00171
35	1-3/8	1524	60	0.00106	0.0270	0.000053	0.00135
38	1-1/2	1727	68	0.00092	0.0234	0.000046	0.00117
45	1-3/4	1981	78	0.00065	0.0165	0.000032	0.00082
54	2-1/8	4216	*166	0.00059	0.0150	0.000030	0.00075
70	2-3/4	4216	*166	0.00029	0.0073	0.000020	0.00052

Call I Squared R for special high resistance values or for hot zones longer than those listed.  
 \* Hot zones longer than 78 inches will have a weld in the hot zone.  
 \*\* All resistance values are +/-20%

The nominal full load voltage and maximum voltage have been computed. When specifying the transformer the nominal full load voltage is usually reduced by 5% to 10% to allow for the minus 20% resistance tolerance of the Starbars. Also, lower voltage taps are usually provided for idling and slow heatups.

To calculate the minimum voltage, take 70% of the nominal voltage. For periodic applications, take 30% of the nominal full load voltage.

Auto transformers may be used if primary voltage is 230 volts or less. They should not be used in a three phase arrangement. Accepted practice limits the secondary voltage on all transformers to 300 volts. Above this refractory voltage leakage becomes a problem. When computing the size of the voltage steps between taps, a value of 5% of the nominal full load voltage is often used. When SCR or thyristor controls are used on the primary, fewer taps are required. For example, if 6 taps are used, the idling tap can be 0.7 x nominal voltage, then each consecutive tap would be 14% higher. For 8 taps, the idling tap would again be 0.7 x nominal voltage, each consecutive tap at 9.1% higher than the preceding.

### EASE OF REPLACEMENT

Starbars can be replaced while the furnace is at operating temperature. The power to the Starbars being changed should be shut off, the spring clips and aluminum braid released, and the old Starbar removed. The new Starbar should be inserted smoothly through the hot furnace with sufficient speed to insure that the aluminum is not melted off the terminal end but not so fast as to cause thermal shock.

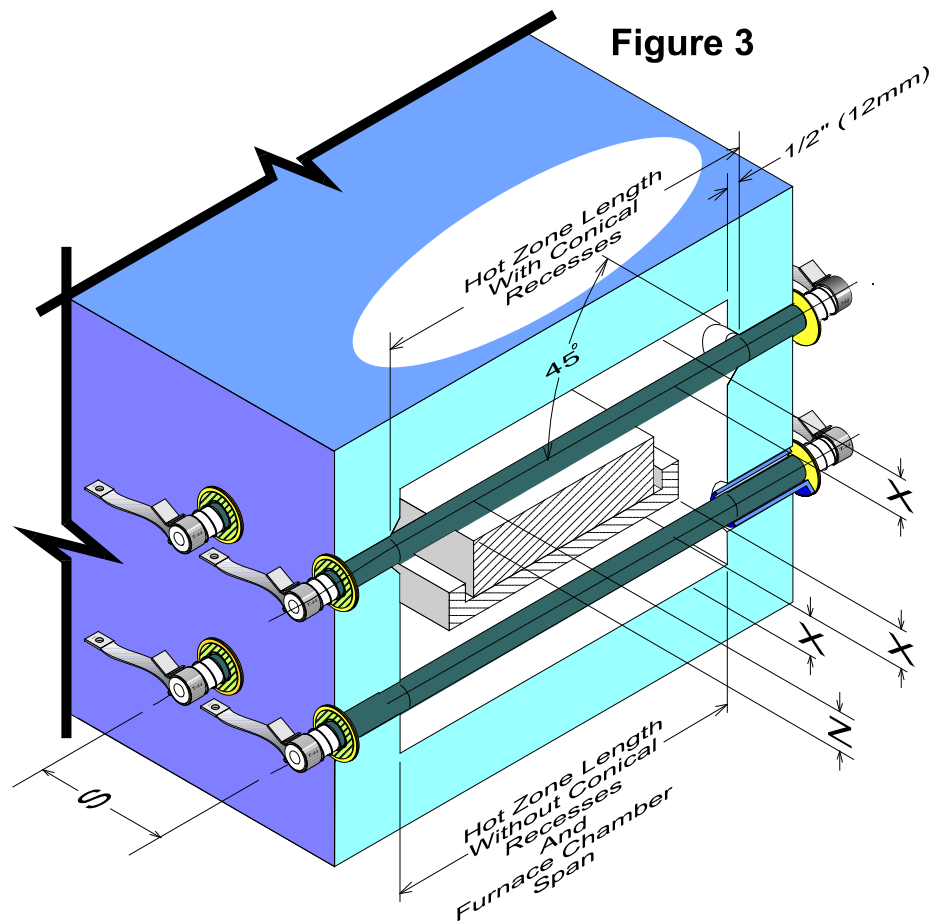

### Recommended Starbar Spacing

$X = 2 \times$  Starbar Diameter is the Minimum,  $1.5 \times$  Starbar Diameter is the absolute Minimum and requires a reduced Starbar Surface Watt Loading

$Z = S \div 1.41$  Minimum for Stationary Loads

$Z = S \div 1.73$  Minimum for Moving Loads

$S = 2 \times$  Starbar Diameters Minimum

X - is the distance from the centerline of the Starbar to any other reflecting surface, such as a refractory wall or product

Z - is the distance from the centerline of the Starbar to a moving or stationary load

S - is the distance from the centerline of the Starbar to the centerline of an adjacent Starbar

## SERVICE LIFE

Starbars increase gradually in resistance with use. This characteristic of increasing in resistance is called aging. Aging is a function of the following:

- (1) Operating temperature
- (2) Electrical loading (usually expressed in watts per square inch or watts per square centimeter of Starbar radiating surface)
- (3) Atmosphere
- (4) Type of operation (continuous or intermittent)
- (5) Operating and maintenance techniques

## MOUNTING

There are no restrictions on the mounting positions of Starbars, although the horizontal and vertical positions are the more common. Extreme caution should be used when mounting to ensure that the Starbars are not placed in tension. There should be adequate freedom to allow for the furnace and Starbars expand and contract independently.

When mounting Starbars vertically they must be supported on the lower end by electrically insulated supports.

Starbars should have their heating sections centered in the furnace chamber so that no portion of the heating section extends into the furnace wall. A conical or truncated cone shaped recess 1/2 inch (13mm) deep is sometimes located on each interior wall where the Starbar passes through. This allows the hot zone to radiate properly and helps maintain a uniform temperature in the kiln.

## FURNACE HEATING CHAMBER

The furnace heated chamber dimension, which the Starbar spans, can be the same as the hot zone length of the Starbar as shown by the Starbars under the load in Figure 3. Alternately the furnace heating chamber dimension, which the Starbar spans, can be one inch (25mm) less than the effective heating length of the Starbar. In this case there must be a 45° conical recess in the furnace wall as shown in Figure 3 for the Starbars above the load. Recommended terminal hole diameters for various refractory walls and Starbar sizes are shown in Table B.

Starbars should not be placed closer than two Starbar diameters to each other or one and one half Starbar diameters to a wall or other reflecting body. If the Starbar is not able to dissipate heat energy equally in all directions, it may cause local overheating and possible failure.

**Table B**  
**Recommended Minimum Refractory Hole Size**

Starbar Diameter		Minimum Hole Diameter Based on Refractory Wall Thickness									
		100	150	200	300	400	3	5	6.5	9	13.5
MM	Inch	MM	MM	MM	MM	MM	Inch	Inch	Inch	Inch	Inch
10	3/8	15	15	16			9/16	9/16	5/8		
11	7/16	16	17	18	20		5/8	11/16	11/16	3/4	
13	1/2	18	19	20	22	--	11/16	3/4	3/4	13/16	--
16	5/8	21	22	23	25	--	13/16	7/8	7/8	15/16	--
19	3/4	25	25	26	28	--	15/16	1	1	1-1/16	--
25	1	31	32	33	35	37	1-3/16	1-3/16	1-1/4	1-1/4	1-7/16
32	1-1/4	38	39	40	42	44	1-1/2	1-1/2	1-9/16	1-9/16	1-11/16
35	1-3/8	41	42	43	45	47	1-5/8	1-5/8	1-11/16	1-11/16	1-13/16
38	1-1/2	44	44	46	48	50	1-3/4	1-3/4	1-13/16	1-7/8	1-15/16
45	1-3/4	51	52	53	55	57	2	2-1/16	2-1/16	2-1/8	2-3/16
54	2-1/8	61	62	63	65	67	2-3/8	2-7/16	2-7/16	2-1/2	2-9/16
70	2-3/4	79	79	79	81	83	3-1/8	3-1/8	3-1/8	3-3/16	3-1/4

The formula for computing the recommended Starbar spacing to obtain an even temperature gradient on the product being heated is shown in Figure 3.

### SPECIFICATIONS AND MATCHING

Starbars have a manufactured tolerance of plus or minus 20% on the nominal resistance. All Starbars are calibrated at least twice prior to shipping to ensure their being within specifications. The calibrated amperage of each Starbar is marked on the carton and right hand end of each Starbar. When installing, arrange Starbars with amperage values as close to each other as available. Longer service life will be obtained when series connected Starbars are matched in resistance. Starbars are shipped as closely matched as possible.

### AVAILABILITY

Starbars can be shipped from stock, or two to three weeks after receipt of an order.

### CUSTOM CONFIGURATIONS

Special sizes and shapes are available. Cold ends can be different lengths. This, for example, would be applicable for furnaces with arched roofs that require longer cold ends through the roof and shorter through the floor.

Another modification is a two-temperature hot zone. This, for example, would be helpful to get additional heat energy into the lower, more densely loaded tunnel kiln. While this special modified hot zone will not create a specific temperature differential, it does offer a convenient way to get more heat energy into a specific area of a furnace.

The right angle (RA) shown here, has all the electrical characteristics of the RR. The cold ends are attached perpendicular to the hot zone. The RA is normally installed with the cold end through the roof of the furnace.

TWO TEMPERATURE  
ODD ENDED STARBAR

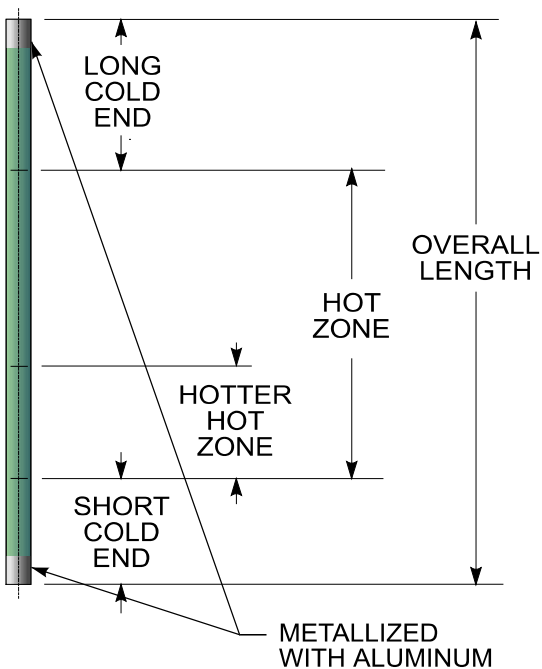

RA

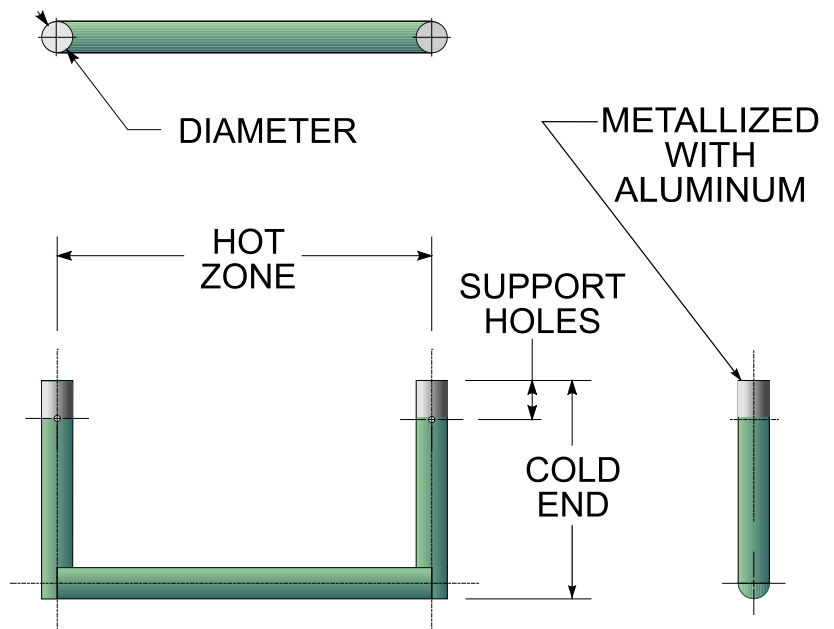

## I SQUARED R ELEMENT CO., INC.

PO Box 390, 12600 CLARENCE CENTER ROAD, AKRON, NEW YORK, USA 14001-0390  
2100

PHONE (01) 716 542-5511 FAX (01) 716 542-



92 à 96 rue Paul Lescop  
F 92000 Nanterre - France

Tél. 33 (0)1 47 21 13 17  
Fax. 33 (0)1 47 24 54 92

contact@refsas.com  
www.REFSAS.COM