

# TYPE SER and TSR, SILICON CARBIDE SPIRAL HEATING ELEMENTS

## GENERAL DESCRIPTION SER

Made of special high-density reaction-bonded silicon carbide, the SER Starbar is a tube with both electrical connections on one end. The hot zone is formed by cutting a double spiral slot which reduces the cross sectional area through which current flows, resulting in higher resistance than the cold end. The cold end is formed by cutting two longitudinal slots along the length of the tube. The SER element is supplied with a ceramic collar cemented to the extremities of the cold end. The cold end of the SER element is flame sprayed with aluminum for a distance of about two inches. Flat braided-aluminum straps are held in compression with stainless steel clamps to this metallized area. The clamp is electrically insulated from the flat braid with high temperature insulation. The aluminum braid is 10 inches (254 millimeters) long and holes are provided for easy connection to the power supply.

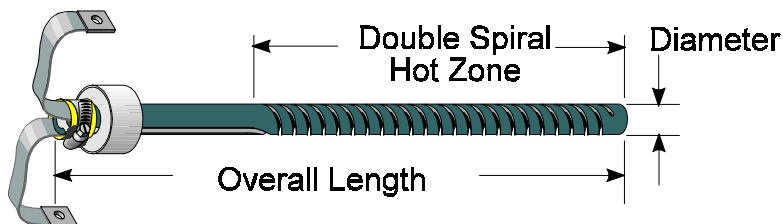

## GENERAL DESCRIPTION TSR

Available in five different diameters, TSR Starbars feature a large inner diameter used as a heating chamber. With both electrical connections on one end, the TSR Starbar is similar to the SER Starbar. The TSR Starbar has a thin wall construction and a clear inner diameter which makes it useful for tube furnace applications. The TSR does not normally require a collar, but one is available. The flat braided-aluminum straps are held in place with a stainless steel clamp. The clamp is electrically insulated from the flat braid with high temperature insulation.

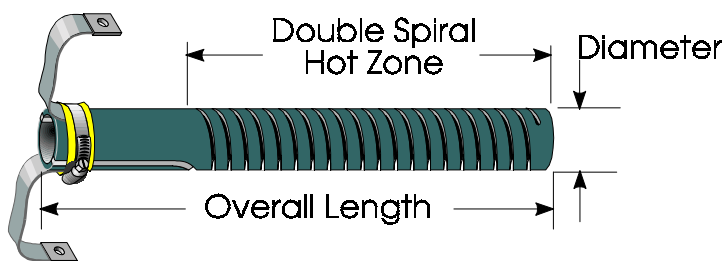

SER and TSR Starbars are described by giving the overall length, the heating section length, and the diameter. As an example, SER 24 x 16 x 1.25 is a Spiral Starbar 24 inch long with a 16 inch hot zone and an outside diameter of 1.25 inch. In millimeters an SER 610 x 406 x 32 is a Spiral Starbar 610mm long with a 406mm hot zone and an outside diameter of 32mm.



## Silicon Carbide Heating Elements



FOURS ET RÉFRACTAIRES

92 à 96 rue Paul Lescop  
F 92000 Nanterre - France  
Tél. 33 (0)1 47 21 13 17  
Fax. 33 (0)1 47 24 54 92  
contact@refsas.com  
[WWW.REFSAS.COM](http://WWW.REFSAS.COM)



S.A. au capital de 545 000€  
RCS Nanterre B 679 800 615  
SIRET : 679 800 615 00040  
NAF : 2320Z

ARCHITECTE DU CHAUD SUR MESURE

## Recommended Maximum Watt Loading (Figure 1)

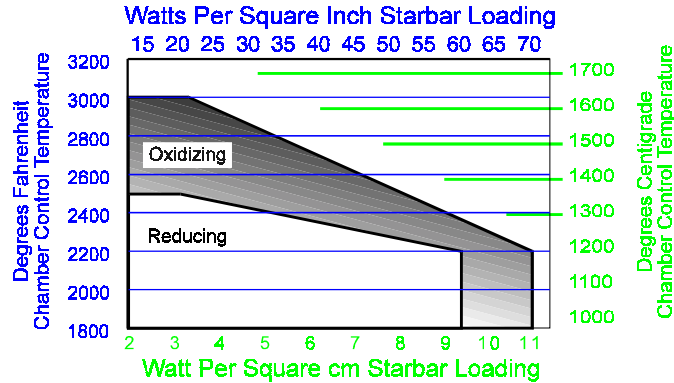

### SUPERIOR PERFORMANCE

At 2.7 gms/cc, this high-density low-porosity element is able to survive severe environments. The high density prevents the internal lattice structure from being oxidized. This element therefore has an extremely slow aging characteristic.

### INTERCHANGEABILITY

Starbars are interchangeable with all silicon carbide heating elements manufactured in the United States as well as higher resistance heating elements manufactured for the Asian and European markets. It is important to provide the nominal electrical resistance when ordering Starbars.

### SIZES AVAILABLE

Starbars can be manufactured in any length up to 80 inches (2032mm). The maximum hot zone length is 40 inches (1016mm) at this printing. Please refer to Table A, page 3, for diameters and lengths available.

### OPERATING TEMPERATURES

In an air or inert atmosphere of argon or helium the SER and TSR Starbars can be operated at furnace temperatures up to 3000°F (1650°C). In reducing atmospheres, the maximum operating temperature is 2500°F (1370°C). See Recommended Maximum Watt Loading Graph, Figure 1.

There is a protective coating of silicon dioxide on the silicon carbide. Hydrogen reduces this coating and causes the Starbar to deteriorate. Nitrogen atmosphere applications are limited to 2500°F (1370°C) and 20 to 30 watts per square inch (3.1 to 4.6 watts per square centimeter) maximum watt loading. Higher surface temperature will result in silicon nitride formation. A thermally insulative layer forms around the Starbar resulting in very high surface temperatures which damage the Starbars.

## Resistance Temperature Characteristics (Figure 2)

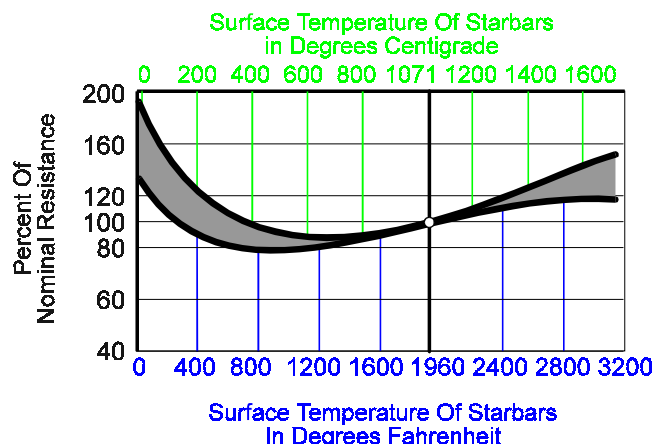

Starbars are test calibrated at a nominal surface temperature of 1960°F (1071°C).

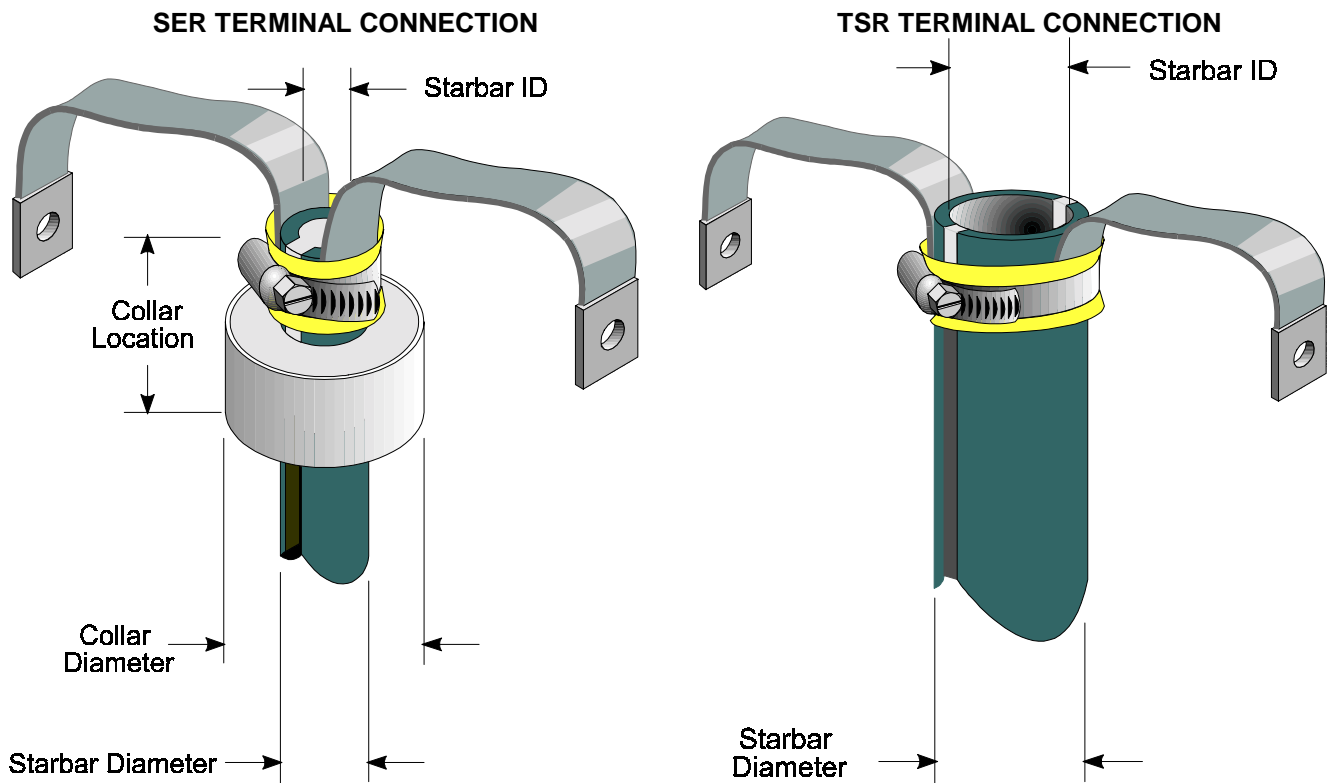

**Aluminum Braid Information:**

- The working length of the SER and TSR aluminum braid is 10 inch (254mm).
- The end clip hole diameter for 50 amp braid is 9/32 inch (7mm), for 100 amp braid and higher is 9/16 inch (14mm).
- The amperage rating of the aluminum braid according to diameter is 1/2 inch (13mm) to 1 inch (25mm) diameter -- 50 amps, 1-1/4 inch (32mm) to 2-1/8 inch (54mm) diameter -- 100 amps, 2-3/4 inch (70mm) diameter -- 400 amps, TSR elements -- 1-3/4 inch (44mm) to 2-1/2 inch (62mm)

<b>Table A</b>															
<b>SER Starbar Dimensions</b>															
Starbar Diameter		Collar Diameter		Collar Location		**Max. Heating Length		**Max. Overall Length		***Max. Load Tube OD		*Starbar ID		Uncut end of hot zone	
mm	in.	mm	in.	mm	in.	mm	in.	mm	in.	mm	in.	mm	in.	mm	in.
13	1/2	38	1-1/2	50	2	250	10	533	21	2	1/16	5	3/16	13	1/2
16	5/8	38	1-1/2	50	2	250	10	559	22	5	3/16	8	5/16	13	1/2
19	3/4	38	1-1/2	50	2	406	16	635	25	6.5	1/4	9.5	3/8	13	1/2
22	7/8	57	2-1/4	50	2	508	20	914	36	9	3/8	12	1/2	13	1/2
25	1	57	2-1/4	50	2	508	20	914	36	11	7/16	14	9/16	13	1/2
32	1-1/4	57	2-1/4	50	2	508	20	991	39	14	9/16	17	11/16	19	3/4
35	1-3/8	57	2-1/4	76	3	610	24	1016	40	18	11/16	21	13/16	19	3/4
38	1-1/2	57	2-1/4	76	3	610	24	1016	40	21	13/16	24	15/16	19	3/4
44	1-3/4	76	3	76	3	610	24	1016	40	24	15/16	27	1-1/16	19	3/4
54	2-1/8	76	3	76	3	610	24	1219	48	30	1-3/16	33	1-5/16	25	1
70	2-3/4	95	3-3/4	100	4	1016	40	1549	61	46	1-13/16	48	1-7/8	38	1-1/2
<b>TSR Starbar Dimensions</b>															
44	1-3/4	The TSR normally does not require a collar, but can be made with one.				305	12	610	24	29	1.14	37	1.46	13	1/2
50	2					305	12	635	25	32	1.25	40	1.57	13	1/2
55	2-1/8					305	12	635	25	36	1.41	44	1.73	13	1/2
62	2-1/2					305	12	660	26	46	1.81	54	2.12	16	5/8
75	3					305	12	660	26	59	2.32	67	2.63	16	5/8
*The SER Starbar inner diameter is normally plugged at the electrical termination end (unless specified as clear ID). The TSR Starbar inner diameter is clear.															
**Recommended maximum lengths = 70% of maximum lengths listed above.															
***The maximum load tube diameter is based on the overall length of the SER or TSR Starbar. Due to different thermal expansion rates, ovalness and lack of straightness of both the Starbar and load tubes, further reductions may be needed.															

## ELECTRICAL CHARACTERISTICS

The silicon carbide Starbar is a linear type resistance heater that converts electrical energy to heat energy -- Joule's Law  $W = I^2 \times R$ , ( $W$  = power in watts,  $I$  = current in amperes,  $R$  = resistance in ohms). The SER Starbar has a negative resistance temperature characteristic from room temperature to approximately 1200°F (650°C). At this temperature it turns positive and remains so throughout its normal operating temperature range. See Typical Resistance/Temperature characteristics Graph, Figure 2, page 2.

Nominal Starbar resistance is measured at the calibrating temperature of 1960°F (1070°C). Nominal resistance values of Starbars in ohms per unit length, are shown in Table B, page 6.

## ELECTRICAL LOADING

Starbars are not sized to a specific wattage output like metallic heating elements. The amount of energy that a Starbar is capable of converting from electrical to heat energy depends on the ambient furnace temperature and atmosphere in which the Starbar is operating.

When calculating the wattage capabilities of a Starbar, the unit of watts output per unit of radiating surface area is used. Figure 1 shows the recommended watt loading for a square inch or square centimeter of radiating surface as a function of furnace temperature.

To determine the recommended wattage capabilities of the Starbars, start with Figure 1. Knowing the furnace temperature and atmosphere in which the Starbars will be operated, follow the temperature line until you intersect the heavy black line, choosing the appropriate line according to the atmosphere in which the Starbar will be operating. Read the loading in watts per square unit of radiating surface that can be applied to the Starbar. To find the total amount of power one Starbar could supply under these conditions, multiply this value by the radiating surface of the Starbar. The radiating surface area is calculated by multiplying the diameter by the hot zone length by pi (3.14).

Example of radiating area:

The SER 24 x 16 x 1.25 has a hot zone length of 16 inches and a diameter of 1.25 inches. The radiating surface area is  $16 \times 1.25 \times 3.14$ , or 63 square inches.

The SER 610 x 406 x 32mm has a hot zone length of 406mm and a diameter of 32mm. The radiating surface area is  $406 \times 32 \times 3.14$  or 40,795 square millimeters -- converted to centimeters is 408 square centimeters.

Example: At 2750°F, in air, a Starbar could be loaded to 35 watts per square inch. Therefore, a Starbar with 10 square inches of radiating surface could supply 350 watts, whereas a Starbar with 200 square inches of radiating surface could supply 7000 watts.

At 1500°C, in air, the Starbar could be loaded to 6 watts per square centimeter. Therefore, a Starbar with 100 square centimeters of radiating surface could supply 600 watts, whereas a Starbar with 2000 square centimeters of radiating surface could supply 12,000 watts.

## POWER SUPPLY

The previous paragraph explained how to calculate the recommended wattage output of the Starbar. The following explains how to compute the electrical requirements to provide the recommended power.

Knowing the wattage output and the resistance of the Starbar you have two parts of an equation with three unknowns. This equation is  $E = \sqrt{W \times R}$ , ( $E$  = nominal full load voltage,  $W$  = rating of the Starbar in watts,  $R$  = resistance of the Starbar in ohms). The resistance of the Starbar can be calculated using the values found in Table B.

Solving for  $E$  determines the voltage required on a nominal-resistance Starbar to provide the wattage

**Table B**  
**SER Electrical Resistance**

Diameter		*Hot Zone Resistance		*Cold End Resistance	
MM	Inch	Ohms / MM	Ohms / Inch	Ohms / MM	Ohms / Inch
13	1/2	.03929	.99784	.00791	.20096
16	5/8	.03153	.80084	.00550	.13960
19	3/4	.02362	.60000	.00394	.10000
22	7/8	.02165	.55000	.00314	.07964
25	1	.01969	.50017	.00233	.05928
32	1-1/4	.01341	.34058	.00152	.03865
35	1-3/8	.01224	.31085	.00110	.02798
38	1-1/2	.01103	.28022	.00116	.02955
44	1-3/4	.00960	.24391	.00079	.01999
54	2-1/8	.00636	.16159	.00073	.01853
70	2-3/4	.00379	.09622	.00042	.01061
<b>TSR Electrical Resistance</b>					
44	1-3/4	.02953	.750	.00000	.00000
50	2	.02953	.750	.00000	.00000
55	2-1/8	.02953	.750	.00000	.00000
62	2-1/2	.02953	.750	.00000	.00000
75	3	.02953	.750	.00000	.00000

\* All Resistance values are +/- 20%

output desired. This assumes a nominal resistance.

Example: A Starbar SER 24 x 16 x 1.25 has a resistance of 5.76 ohms and 63 square inches of radiating surface. Loading to 40 watts per square inch this Starbar could provide 2500 watts. To find the nominal voltage solve for E.

$$E = \sqrt{W \times R}$$
$$E = \sqrt{2500 \times 5.76}$$
$$E = 120 \text{ volts}$$

Starbars may be connected in parallel, series, or any combination thereof. Parallel connections are preferred because if the resistance of one or more Starbars increases, its portion of the load will be reduced and the group will remain in balance.

In a parallel arrangement the voltage across all the Starbars is the same. In the formula  $W = E^2 \div R$  ( $W$  = watts,  $E$  = voltage,  $R$  = resistance) it can be seen that, the greater the resistance, the lower the wattage output. The Starbars in the parallel circuit with the lowest resistance will supply more heat energy and therefore operate at a higher temperature.

This higher Starbar temperature will cause it to gradually increase in resistance until all the Starbars have the same resistance. At this time all the Starbars should have approximately the same resistance values and surface temperatures and therefore remain in balance.

To compute the network resistance of a group of Starbars the following formula may be used:  
 $R_n = R \times S \div P$  ( $R_n$  = network resistance,  $R$  = resistance of Starbar,  $S$  = number of Starbars connected in a series,  $P$  = number of parallel circuits).

Example: Eight Starbars SER 24 x 16 x 1.25 ( $R = 5.76$  ohms) connected 2 in series ( $S = 2$ ) and 4 parallel groups ( $P = 4$ ).

$$R_n = R \times S \div P$$
$$R_n = 5.76 \times 2 \div 4$$
$$R_n = 2.88 \text{ ohms}$$

To compute the nominal network voltage required to power a set of Starbars, a combination of the previous two formulas is used as follows:  $E_n = \sqrt{W_t \times R_n}$ , ( $E_n$  = nominal network voltage,  $R_n$  = network resistance,  $W_t$  = total wattage output).

Example: Eight Starbars SER 24 x 16 x 1.25 ( $R = 5.76$  ohms) connected 2 in series, 4 parallel groups. Each Starbar provides 2500 watts.  $W_t = 8 \times 2500 = 20,000$  watts.  $R_n = 2.88$  ohms.

$$E_n = \sqrt{W_t \times R_n}$$
$$E_n = \sqrt{20,000 \times 2.88}$$
$$E_n = 240 \text{ volts}$$

The resistance of Starbars increases gradually during their useful life. Therefore some means of keeping the power input to the kiln or furnace at a level sufficiently high to maintain the desired temperature is required.

Historically, expensive voltage varying equipment such as multiple tap transformers or saturable reactors were recommended for all but the very low temperature applications.

Spiral Starbars can be used directly on the line (fixed voltages) at temperatures up to 2500°F (1370°C). To compensate for the reduced output as the Starbars gradually age or increase in resistance, the furnace or kiln is initially overpowered by 25% to 50%. This type of arrangement eliminates the expensive voltage varying equipment and has proven very satisfactory in many applications. It is not recommended when fine process temperature control is required.

Assume a furnace will require approximately 20,000 watts after all heat losses and load factors have been considered. Increasing this 20,000 by 25% to 50% gives a wattage requirement of between 25,000 and 30,000 watts.

By taking another look at the previous examples it can be seen that 10 Starbars SER 24 x 16 x 1.25 connected two in series, five parallel groups on 240 volts would supply 25,000 watts. If 12 Starbars of the same size Starbars were used, the output would be 30,000 watts.

Twelve Starbars connected four in series, per phase, in a delta, on 240 volts would make a balanced three phase 240 volt network.

The temperature of the kiln or furnace is controlled by an off-on controller. When the Starbars are new, they will only be powered for 20/25 or 20/30 of the time (the ratio of the power needed to the power available). As the Starbars increase in resistance, they will be on for a greater percentage of the time. When they have increased in resistance to a point at which they supply 30,000 watts, they will be on 100% of the time. A SCR (silicon controlled rectifier) or thyristor can also be used.

For applications where close temperature control is desired and/or for temperatures above 2500°F (1370°C), a device for increasing the voltage to the Starbars is required. There are several methods of providing this variable voltage source.

1. The multiple tap transformer is the most common because it is usually the least expensive. The secondary of the transformer is provided with taps which usually vary in number from 10 to 36. By carefully selecting the voltage taps, the correct voltage output to match the resistance of the Starbars over their complete useful life can be made.
2. Saturable reactors and induction regulators are used to provide a stepless voltage control. They are also sometimes used with multiple tap transformers.
3. Capacitor controls are used infrequently. They, of course, will tend to improve a power factor which makes their use desirable in some areas.
4. Silicon controlled rectifiers (SCR) have become quite popular with the advances in solid state devices.

To compensate for the reduced output as the Starbars increase in resistance, a voltage range is required that will compensate for a 100% increase in the Starbar's resistance. The following formula may be used to figure  $E_{max}$ :  $E_{max} = \sqrt{Wt \times Rn} \times 1.5$ , ( $E_{max}$  = recommended maximum voltage required to compensate for increase in resistance due to aging and resistance tolerance,  $Wt$  = rating of transformer in watts,  $Rn$  = network resistance of the Starbars, 1.5 = minimum margin to accommodate the doubling of the Starbar network resistance and the plus 20% resistance tolerance). A higher value will offer slightly longer usable service life.

Example: A transformer is rated at 24 KVA and has a computed nominal full load voltage of 240 volts. ( $Rn = 2.88$ ,  $Wt = 20,000$  for 8 Starbars)

$$\begin{aligned} E_{max} &= \sqrt{Wt \times Rn} \times 1.5 \\ E_{max} &= \sqrt{(20,000 \times 2.88)} \times 1.5 \\ E_{max} &= \sqrt{57,600} \times 1.5 \\ E_{max} &= 360 \text{ volts} \end{aligned}$$

The nominal full load voltage and maximum voltage have been computed.

When specifying the transformer, the nominal full load voltage is usually reduced to allow for the minus 20% resistance tolerance of the Starbars and slow furnace heatup.

To calculate the minimum voltage, take 70% of the nominal voltage. For periodic applications, take 30% of the nominal full load voltage.

Auto transformers may be used if primary voltage is 230 volts or less. They should not be used in a three phase arrangement. Accepted practice limits the secondary voltage on all transformers to 300 volts. Above this, refractory voltage leakage becomes a problem.

When computing the size of the voltage steps between taps, a value of 5% of the nominal full load voltage is often used. When SCR or thyristor controls are used on the primary, fewer taps are required. For example, if 6 taps are used, the idling tap can be 0.7 x nominal voltage, then each consecutive tap would be 14% higher. For 8 taps, the idling tap would again be 0.7 x nominal voltage, each consecutive tap at 9.1% higher than the preceding.

### EASE OF REPLACEMENT

SER Starbars can be replaced while the furnace is at operating temperature. The power to the Starbars being changed should be shut off, the aluminum braids disconnected from the buss, and the old Starbars removed. The new Starbar should be inserted smoothly through the hot furnace but not so fast as to cause thermal shock.

### SERVICE LIFE

Starbars increase gradually in resistance with use. This characteristic of increasing in resistance is called aging. Aging is a function of the following:

1. Operating temperature
2. Electrical loading - usually expressed in watts per square inch or watts per square centimeter of Starbar radiating surface
3. Atmosphere
4. Type of operation (continuous or intermittent)
5. Operating and maintenance techniques

### MOUNTING

SER Starbars can be mounted vertically or horizontally. When mounted horizontally, the hot end does not need to be supported. When mounting the element horizontally the slot in the terminal end should not come in contact with the insulation in the wall of the furnace or kiln. This is most easily accomplished by placing the slot in a horizontal position. The terminal holes should also be 10% larger than the diameter of the element. Extreme caution should be used when mounting to ensure that the Starbars are not placed in tension. There should be adequate freedom to allow for the furnace and Starbars to expand and contract independently.

Starbars should have their heating sections centered in the furnace chamber so that no portion of the heating section extends into the furnace wall. A conical or truncated cone shaped recess 1/2 inch (13mm) deep is sometimes located on the interior wall where the Starbar passes through. This allows the hot zone to radiate properly and helps maintain a uniform temperature in the kiln.

### FURNACE HEATING CHAMBER

The furnace heated chamber dimension, which the Starbar spans, can be the same as the Starbar hot zone as shown in Figure 3 and Figure 4, page 8. The recommended terminal hole diameter is calculated by increasing the Starbar outer diameter by 20% for sizes up to and including 1-3/8 inch (35mm), and a 10% increase for larger sizes. Table C shows these recommended minimum refractory hole diameters based on the Starbar size.

<b>Table C</b>			
<b>SER Recommended Minimum Refractory Hole Diameter</b>			
Starbar Diameter		Recommended Minimum Refractory Hole Diameter	
MM	Inch	MM	Inch
13	1/2	16	5/8
16	5/8	19	3/4
19	3/4	23	7/8
22	7/8	27	1-1/16
25	1	30	1-3/16
32	1-1/4	39	1-1/2
35	1-3/8	42	1-5/8
38	1-1/2	42	1-11/16
44	1-3/4	49	1-15/16
54	2-1/8	60	2-3/8
70	2-3/4	77	3-1/32
<b>Recommended Minimum Refractory Hole Diameter for TSR Cold End</b>			
44	1-3/4	49	1-15/16
50	2	55	2-1/4
55	2-1/8	61	2-11/16
62	2-1/2	69	2-3/4
75	3	84	3-5/16

Starbars should not be placed closer than two Starbar diameters to each other or one and one half Starbar diameter to a wall or other reflecting body. If the Starbar is not able to dissipate heat energy equally in all directions, it may overheat and possibly fail.

The formula for computing the recommended Starbar spacing to obtain an even temperature gradient on the product being heated is shown in Figure 3, below.

**Figure 3**

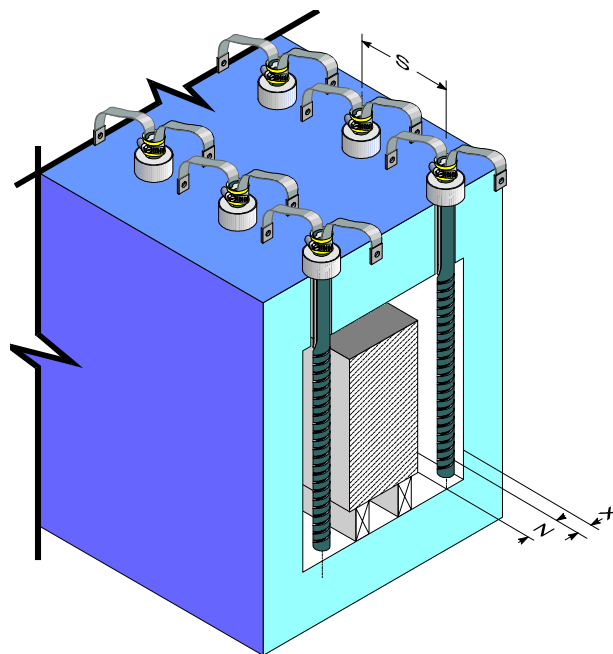

### RECOMMENDED SER STARBAR SPACING

$X = 2 \times$  Starbar diameter is the minimum,  
 $1.5 \times$  Starbar diameter is the absolute minimum  
 and requires a reduced Starbar surface watt  
 loading

$Z = S \div 1.41$  minimum for stationary loads

$Z = S \div 1.73$  minimum for moving loads

$S = 2 \times$  Starbar diameters minimum

X - distance from the centerline of Starbar to any reflecting surface, such as a refractory wall or product

Z - distance from the centerline of the Starbar to a moving or stationary load

S - distance from centerline of the Starbar to the centerline of an adjacent Starbar

## SPECIFICATIONS AND MATCHING

Starbars have a manufactured tolerance of plus or minus 20% on the nominal resistance. All Starbars are calibrated at least twice prior to shipping to ensure their being within specifications. The calibrated amperage of each Starbar is marked on the carton and collar of each Starbar. When installing, arrange Starbars with amperage values as close to each other as available. Longer service life will be obtained when series connected Starbars are matched in resistance. Starbars are shipped as closely matched as possible.

## AVAILABILITY

Starbars can be shipped from stock, or two to three weeks after receipt of an order.

## CUSTOM CONFIGURATIONS

The ID of the SER cold end is normally plugged. Alternatively, the SER is available with a clear ID which allows it to be used as a tube heater. The SER should be used as a tube heater rather than the TSR whenever possible because the wall is thicker making it stronger. The TSR should be used only when the SER ID is not large enough.

Special higher electrical resistance values are available. This is accomplished by machining a smaller spiral width. Therefore, very high resistance and/or long hot zone lengths are not practical. Lower than standard resistances are not recommended.

## TSR Starbar used as Tube Heater

Refer to Table A for Recommended Maximum Load Tube Diameters.

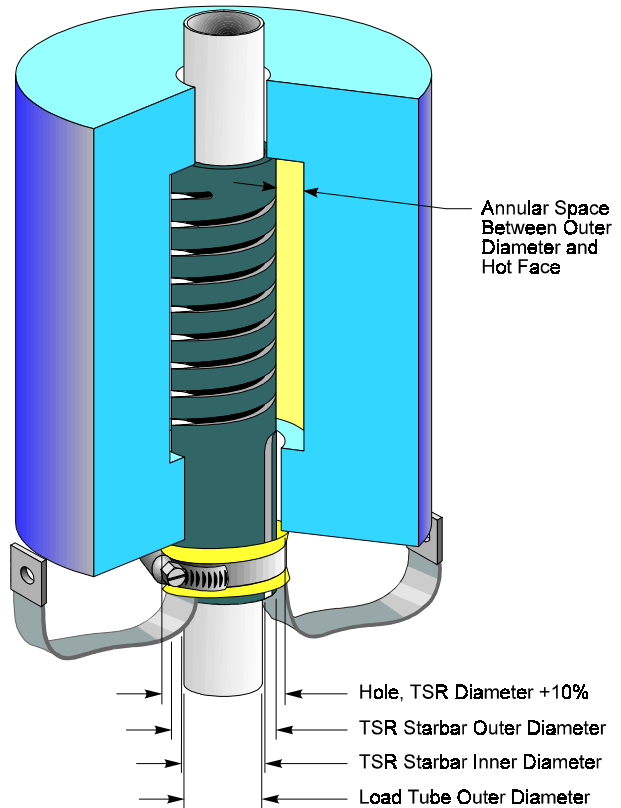
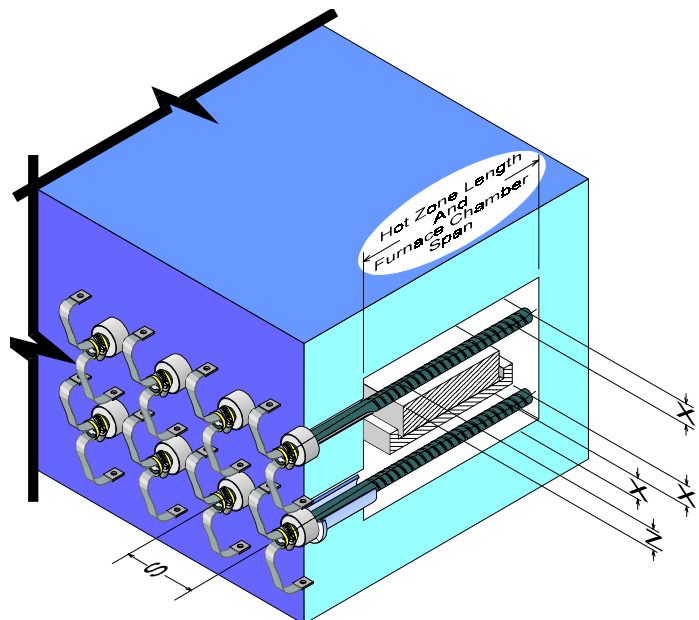

Figure 4

## SER Starbars Positioned Horizontally



## I SQUARED R ELEMENT CO., INC.

PO Box 390, 12600 CLARENCE CENTER ROAD, AKRON, NEW YORK, USA 14001-0390

PHONE (01) 716 542-5511

FAX (01) 716 542-2100



92 à 96 rue Paul Lescop  
F 92000 Nanterre - France

Tél. 33 (0)1 47 21 13 17  
Fax. 33 (0)1 47 24 54 92

contact@refsas.com  
www.REFSAS.COM